



A New Adjustable Gate Time Counter from a New -hp- Affiliate

FOR some time there has been in operation a new -hp- affiliate which has now developed a new counter for the many mechanical and industrial applications such as tachometry and fuel flow measurements to which electronic counters bring increased accuracy and speed of measurement. The new -hp- affiliate (Dynac, Inc.) is described in another article in this issue.

SEE ALSO:
"A New Instrumentation Service," p. 3

The new -dy- Model 2500 counter has been specifically designed to display in illuminated numerals the values metered by transducers of the type that converts physical quantities to proportional electrical frequencies. Such transducers include flow meters, tachometer generators, and pressure transducers as well as many telemetering systems.

To make the -dy- 2500 especially suitable

for such work, it has been designed so that panel controls can select any desired sampling interval (gate time) from 0.1 millisecond to 0.9999 second in 0.1 millisecond steps^{1, 2}. In practical terms this means that the instrument will introduce into the measurement a calibration constant such that the measured quantity is displayed *directly in any desired units* such as rpm or rps, gallons/hour or minute, gallons/revolution, revolutions/revolution, etc. The adjustable gate time feature further enables *changes* in any of these quantities to be read *directly on a percentage basis*, i.e., so that the counter displays the measured quantity as a percentage of its original value.

¹The counter is also available with gate times up to 9.9999 seconds for applications where higher resolution measurements are desired or where slow speed phenomena are to be measured.

²A special form of this counter with 18 preset gate times for the 18 RDB FM/FM channels is also available. See second article in this issue.

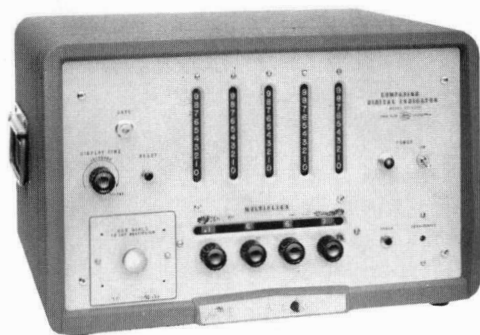
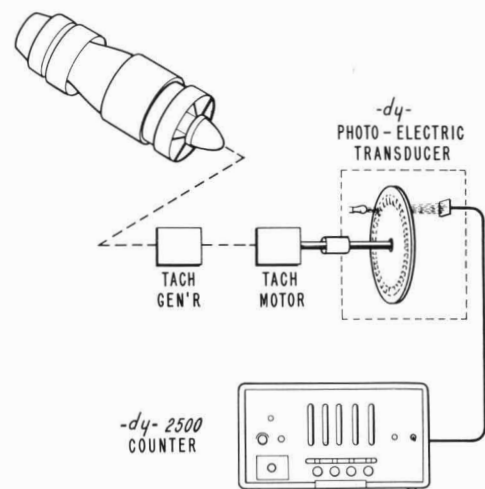

Fig. 1. Gate time in new -dy- 2500 Counter is adjustable in 0.1 millisecond steps from 0.1 millisecond to 0.9999 second to enable measurements to be made directly in any desired unit such as rpm or gallons/hour.

Fig. 2 (right). New photo-electric transducer enables counter to make rapid high-resolution measurements from the tachometer motors incorporated in engine test stands and of many other rotating devices.



An especially valuable application of the new counter occurs in the field of flow measurements. In this type of work the counter can be used to obtain flow information in at least three direct-reading forms:

- Directly in fuel mixture ratio.
- Directly in volume units (gals./minute or hour).
- Directly in gravimetric units (pounds/minute or hour).

Flow measurements in other direct-reading forms such as percentage units, revolutions/gallon, etc., are also readily made.

MIXTURE RATIOS

To make the counter convenient for measuring mixture ratios, it has been provided with a terminal which enables an external frequency to operate the gate "time." When this feature is used, the gate time controls are converted from providing 9999 increments of 0.1 millisecond each to providing 9999 increments of 1 cycle (period) of the external frequency. Mixture ratios can thus be made with an equipment arrangement like that indicated in the illustration. In this arrangement a flow meter is connected in each of the two fuel lines. The outputs from these meters are connected to the two inputs on the counter. The counter will then directly display the ratio of

FLOW MEASUREMENTS

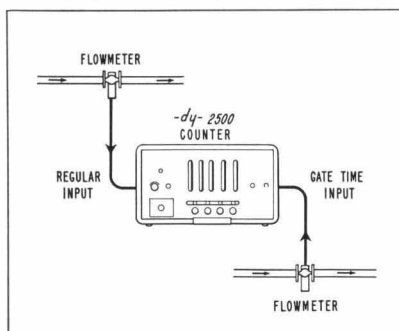

flow in meter connected to regular counter input
 flow in meter connected to gate time input

The value of the adjustable gate time in this type of measurement lies in the fact that the two flow meters need not have identical output rates for identical flow rates. The counter will automatically compensate for different flow meter constants when the gate time controls are set to the factor k , where

$$k = \frac{\text{output frequency of flow meter 1}}{\text{output frequency of flow meter 2}}$$

when each flow meter is passing the same volume per unit time. If the flow meters are identical, k will thus be 1. (In most cases it will be desirable to multiply k by some integral power of 10

such as 100 to obtain higher resolution in the displayed value.)

FLOW IN VOLUME OR GRAVIMETRIC UNITS

Flow can be measured in volume or gravimetric units merely by selecting a gate time such that a unit flow rate in the flow meter will result in a reading of some integral power of 10 on the counter. A flow meter that produces 150 cps for a flow rate of 1 gallon/minute, for example, would be used with a gate time of $1/150$ cps = 0.0067 second. This would give a unit flow reading of 1 on the counter. To obtain a unit flow reading of higher resolution such as 1.0 or 1.00, then, a gate time of 0.0667 or 0.6667 second would typically be used. With a gate time of 0.6667 second, each flow rate of 1 gallon/minute would cause a reading of 1.00 on the counter. Flow rate in gallons/hour would be obtained by using a gate time 60 times as long, i.e., 60×0.0067 second = 0.4000 second.

Readings directly in gravimetric units would be obtained as above except by introducing a weight constant into the time base used. To measure water with a weight of 8.3 pounds/gallon, for example, the gate time for volume measurements should be multiplied by 8.3. The reading on the counter would then occur directly in pounds/minute or hour.

NEW PHOTO-ELECTRIC TACHOMETRY TRANSDUCER

Tachometry measurements with the new counter are simplified even further by a new photo-electric transducer. This new unit is designed to operate from such devices as the slave tachometer motors commonly used with engine test stands or from any rotating mechanism that can withstand a slight mechanical loading (that of an unloaded shaft with a film disc).

Fig. 2 (front page) shows how the transducer and counter are used in a typical engine test set-up. The engine under test drives the tachometer motor from the tachometer generator, which is mounted on the engine. The tachometer motor can then be mechanically coupled to the new transducer. Since the transducer introduces only a slight loading, motor speed is unaffected. The transducer thus produces an accurate proportional frequency signal which is

counted by the counter to give a direct reading in rpm, rps, or other arbitrary units.

Basically, the transducer consists of a disc with peripheral transparent slots which interrupt a light beam passing to a phototube. Since the disc in the transducer can be provided with as many as 360 slots, rotary speed measurements can be made with high resolution and in a very short time. Using a disc with 60 slots, for example, would permit a 2,000 rpm ($33\frac{1}{3}$ rps) engine speed to be measured to four significant figures using a nominal 1-second gate time (actually 0.9999 second). If the measurement were desired in rps instead of rpm, the gate time would merely be changed to $1/60$ or $1/6$ second. The counter-transducer combination will permit rotational speeds above 30,000 rpm to be measured.

The new transducer has been designed with several features that

(Continued on P. 4)

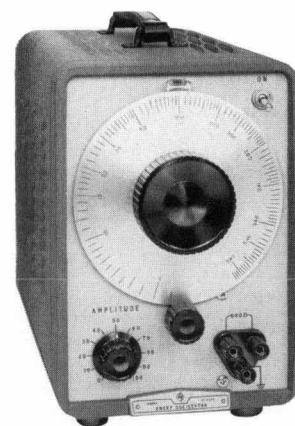

5 CPS - 5 KC SWEEP OSCILLATOR

Many physical investigations such as vibration tests have had a requirement for a single-band wide-range oscillator. This need has been met by a new -dy- sweep oscillator (Model 2200) which covers a 1000:1 range in a single dial sweep. The oscillator operates from 5 cps to 5 kc with a single turn of the dial and has a true logarithmic dial calibration above 50 cps with an approximate log calibration below that frequency. The instrument is provided with a tuning dial shaft extension at the rear which enables it to be coupled to a motor drive system if desired.

DYNAC, INC. - A NEW SERVICE FOR SPECIALIZED INSTRUMENTATION

EARLY this year *-hp-* established a new affiliate designed to serve customers who had need for specialized instrumentation on either a large or small scale. This new affiliate, Dynac, Inc. (symbolized by *-dy-*), was established with Robert E. Rawlins as general manager and a staff drawn from the *-hp-* organization as well as externally. Mr. Rawlins has had wide experience in electronics engineering and instrumentation and will be known personally to many readers.

DIGITAL TESTING SYSTEM

An important field where *-dy-* has been of service is in supplying instrumentation in the form of multi-channel automatic data handling systems. In this field *-dy-* typically provides complete systems which sense the physical phenomena of interest, multiplex it for transmission,

and record it together with coding and timing signals on commercially available recorders.

Playback facilities of these systems include simultaneous multi-channel calibration-corrected signals in digital and analog form. The systems also provide for automatic print-out by devices currently under development.

HIGH OUTPUT 8.5-10 KMC TEST SET

A special-purpose instrument that *-dy-* has produced to meet needs for unusually high outputs from an X-band signal generator is a modification of the *-hp-* Model 624C 8.5-10 kmc test set. In its standard form this instrument is designed to provide c-w or pulsed outputs over a 1 mw to -100 dbm output level range and to measure external power

(Cont'd on P. 4)

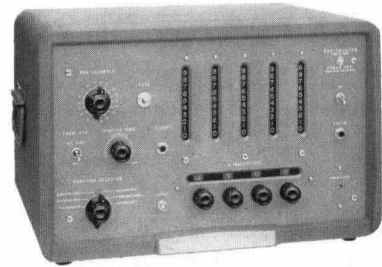

TELEMETERING COUNTERS

Among the new *-dy-* instruments is a second adjustable gate time counter designed especially for simplifying and economizing tests on RDB FM/FM telemetering systems. This second counter (Model 5020) is arranged with 18 preset gate times which correspond to the center frequencies of the 18 RDB channels. The gate time for any desired channel can be selected with a panel control which is calibrated directly with the channel numbers. To set the output frequency of a signal source to the proper channel frequency, it is only necessary to set the counter switch to the appropriate channel number while monitoring the signal source with the counter. The counter will then display the period of the source frequency as a percentage of the period of the channel's assigned center frequency. Relatively non-technical personnel can thus make response measurements without having to deal with complicated frequency data, since the same percentage figures are used with every channel.

Another field of considerable importance in which *-dy-* has been active is in applying the *-hp-* traveling-wave amplifier with other equipment to form microwave signal generators capable of simulating nearly any desired type of microwave signal. In this work *-dy-* has been closely allied with the *-hp-* development staff. As mentioned in previous articles^{1, 2}, the *-hp-* traveling-wave amplifier was capable of serving as an extremely flexible modulator-amplifier suitable for forming a microwave signal generator with very useful properties for systems work. These properties are especially useful for testing radar systems of all types including missile guidance, fire control and detection systems which produce range, bearing, and moving target information.

The usefulness of these generators can be described with reference to the illustration.

In the first place it will be seen that the generators are distinguished by a MOPA circuit arrangement which offers the ad-

RADAR SIGNAL SIMULATORS

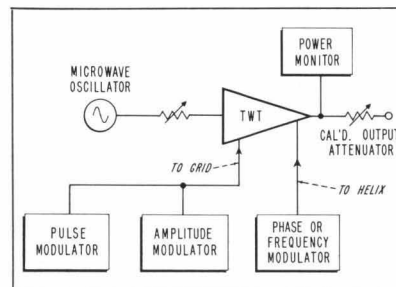

vantage of an oscillator isolated from the modulated stage. Consequently, there is little effect on the carrier center frequency when modulation is applied or changed. The generators can operate over a waveguide band in the 2 - 12 kmc range but the klystron in the oscillator circuit is selected to meet particular requirements. Following the oscillator is a level-setting attenuator which in turn is followed by the traveling-wave amplifier. As mentioned in the referenced articles, these amplifiers are capable of amplitude, pulse, and phase or frequency modulation. These modulations can be obtained either alone or in any combination and are further distinguished by the following characteristics:

- Pulse modulation has very fast rise

times and jitter-free operation, characteristics not available in any other test pulse source.

- Through use of the serrodyne method³ of phase modulation, small microwave frequency displacements which simulate doppler effects and c-w radar ranging echoes can be obtained.
- Doppler frequency shifts can be generated simultaneously with any other type of modulation necessary to test essentially any type of radar system.
- Amplitude modulation which simulates lobing modulation can be obtained simultaneously with either pulse modulation or frequency displacements.
- Fast phase shifts similar to those obtained in systems subject to fast bearing changes can be simulated.
- Target echo fluctuations can be simulated to evaluate radar field performance.
- The amplifiers in the generators can also be used as homodyne detectors for linear weak-signal detection.
- The oscillator signal as well as the modulated signal is available from the generators for testing coherent radar systems.

The generators can thus simulate signals which in some cases were previously encountered only in field tests.

³ See footnote 2.

¹ P. D. Lacy and D. E. Wheeler, *New Broadband Microwave Power Amplifiers Using Helix-Coupled TWT's*, Hewlett-Packard Journal, Vol. 6, No. 3-4, Nov.-Dec., 1954.

² P. D. Lacy and Geo. W. C. Mathers, *New TWT Amplifiers with Provision for Simulating Special Microwave Signals*, Hewlett-Packard Journal, Vol. 7, No. 5, January, 1956.

levels from -6 to +28 dbm. The instrument also contains a precision frequency meter so that output frequencies can be set precisely.

The modified instrument provided by -dy- typically produces a maximum of about 60 milliwatts over the 8.5-10 kmc range. The instrument is thus useful for measurements where high attenuations are encountered in the measurement process or where the performance of

sensitive devices in the presence of high signal levels is to be studied.

OTHER SPECIAL INSTRUMENTS

A further function of the -dy- organization is to assist customers who have need for special versions of standard Hewlett-Packard instruments. Many special counters and timers, for example, have been supplied. Since the -dy- organization is specifically adapted to handle special instrumentation requirements, it is in a position to offer services

not previously available.

-dy- is represented by the same engineering representatives that represent the Hewlett-Packard organization. You are invited to contact these representatives at any time or to correspond directly with the -dy- organization at the following address:

Dynac, Inc.
395 Page Mill Road
Palo Alto, California
Phone: DAvenport 5-4459

-dy- 2200 (CONT'D FROM P. 2)

make it convenient to use and give it long life. It operates from a 6.3-volt supply (provided by the -dy- 2500) and uses transistors rather than vacuum tubes. The light source in the transducer is operated at a relatively low voltage so that very long lamp life will be obtained. Finally, the output voltage does not vary with frequency over the rated range so that sensitivity problems such as frequently occur at low speeds with flux-cutting devices are not introduced.

PERCENTAGE CHANGE ROTATIONAL MEASUREMENTS

To facilitate studying the effect of various factors on engine performance, the counter-transducer combination can also be used to obtain rotational speed measurements in percentage form. To obtain readings directly in percentage units, the variable gate time feature of the counter is used to obtain an initial reading on the counter of 100, 100.0, or 100.00, as desired. If an initial engine speed of 2,000 rpm and a transducer disc with 60 slots were being used, for example, a gate time of 0.5000 second would give a reading of 100.0 (%). Subsequent changes in engine speed would then be shown on the counter as a change from this 100% initial value.

PLUG-IN TIME BASE SELECTORS

Another of the special features of the new counter is that it is provided with a panel plug-in device that

automatically provides a single predetermined gate time for the counter and at the same time disables the manual gate time controls so that no other gate time can be obtained. This selector is designed for applications which involve making routine measurements, all of which require the same gate time, such as in tachometry and flow measurements. The selector enables these measurements to be made with minimum possibility of selecting an incorrect gate time. The selector can be arranged to give any one of the gate times within the instrument's range and the time for which the selector is set can be changed at any time. Additional selectors can be supplied for use where more than one gate time is commonly used.

When not in use, the selector is inserted into its panel recess in an inverted position. This disables the selector and restores to operation the manual gate time controls.

HIGH SENSITIVITY OPTION

The counter has been designed with a sensitivity such that it will operate from a 0.2-volt rms signal. This is adequate for the majority of applications and has the advantage that it minimizes possible noise problems in external circuits, but the instrument is also available with an optional higher sensitivity of 5 millivolts.

Other optional features are also available for the new counter. These are listed in the accompanying specifications.

**SPECIFICATIONS
-dy-
MODEL 2500**

- Range: 1 cps to 100 kc.
- Accuracy: ± 1 count \pm stability of crystal (below).
- Stability: 1 part in 10^5 short term.
- Registration: 5 places. Total count capacity 99,999.
- Input Requirements: 0.2 v rms minimum (5 mv rms, optional*).
- Input Attenuator: Adjusts sensitivity from 0.2 v to 100 v rms to overcome noise.
- Dual Input: Connector and switch for optional second input permits direct ratio measurements of unknowns.
- Input Impedance: Approximately 1 megohm. 50 mmf shunt.
- Multiplier: Adjustable in steps of 1 from 1 to 9999 (with 5 controls, 1 to 99999*). With single input, multiplier adjusts gate time from 0.0001 to 0.9999 seconds (or 0.001 to 9.9999 seconds*) in 0.1 millisecond increments.
- Display Time: Variable from 1 to 10 seconds; or display can be held indefinitely.
- Reset to Zero: Controlled automatically by display time generator or manually by reset button for "infinite" display time.
- Self Check: Counts time-base frequency for any selected gate time.
- Connectors: BNC and standard phone jack on rear panel.
- Phototube Input: Supply voltage for 1P41 (or equal) phototube.
- Accessory Sockets: Jones plug supplies 6.3v a-c, 1.0 a. Connector for -hp- Model 560A Digital Recorder.
- Power Supply: 115/230v $\pm 10\%$, 50/60 cps, 260 watts.
- Size: Cabinet mount: 20 $\frac{3}{4}$ " wide, 12 $\frac{1}{2}$ " high, 14 $\frac{1}{2}$ " deep. Rack mount: 19" wide, 10 $\frac{1}{2}$ " high, 14 $\frac{1}{2}$ " deep.
- Weight: Cabinet mount 50 lbs. net; shipping weight 95 lbs. Rack Mount: 45 lbs. net; shipping weight 90 lbs.
- Accessories Provided: 44" RG-58/U cable terminated one end with UG-88/U Type BNC connector.
- Accessories Available: Multiplier Selector Plug, -dy- Part 2500-52 (one supplied with instrument), \$27.50.
- Price: Model 2500 Computing Digital Indicator, with dual input, rack mount: \$1330.00. Cabinet mount (as shown): \$1350.00.
- *Options: Fifth Multiplier: Add \$75.00. Gate time 0.001 to 9.9999 seconds: No charge. 5 mv RMS sensitivity: Add \$20.00. Temp. stabilized crystal: Add \$25.00.

Prices f.o.b. Palo Alto, California
Data subject to change without notice